



GLASSCRAFTERS INC.

GLASSCRAFTERS, INC.
193 Vetrans Blvd., Carlstadt, NJ 07072

1+ (888) 683-1362 (F) 1+(201) 525-1117
sales@glasscraftersinc.com

EPIC™ SERIES

Model By-Pass Sliding Doors Installation Instructions

 Tub or Shower By-Pass Sliding Doors
with Inline Panel ETI - ESI or with Inline Buttress Panel ETBI-ESBI

By Pass Sliding Doors

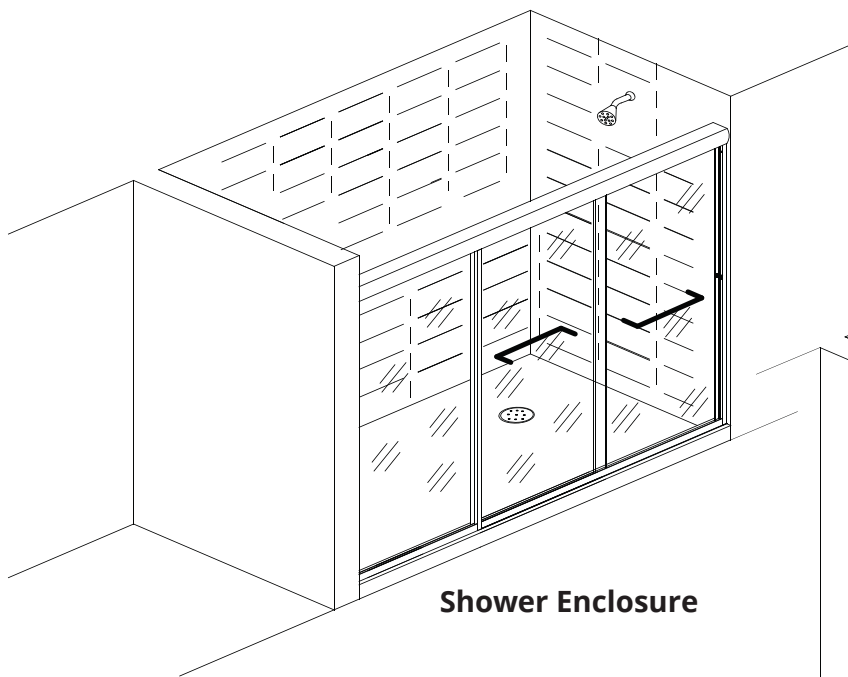

Shower Enclosure

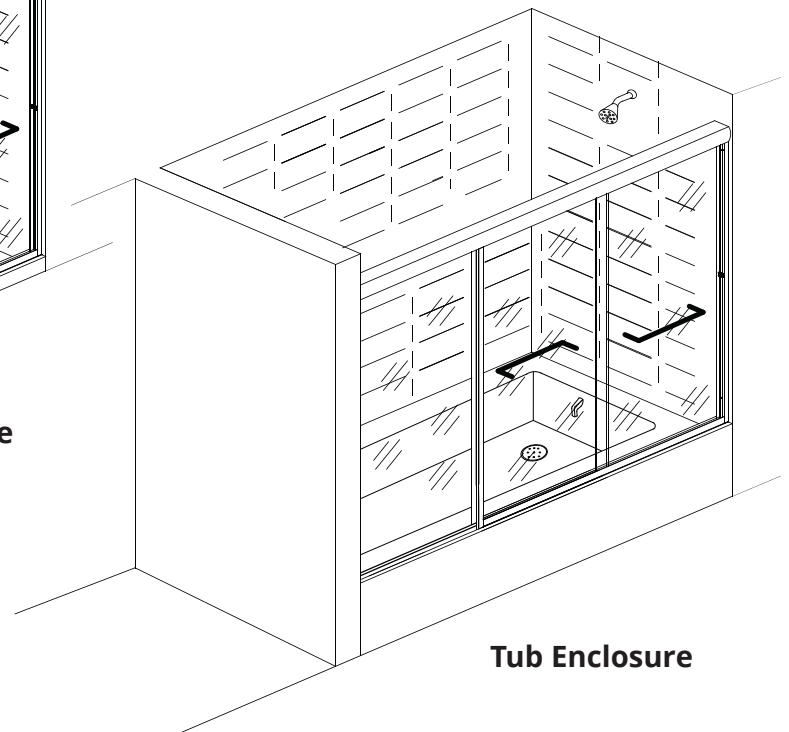

Tub Enclosure

IF YOU NEED REPLACEMENT PARTS OR HAVE INSTALLATION QUESTIONS,
PLEASE CALL OUR CUSTOMER SERVICE REPRESENTATIVES.
INSTALLATIONS SHALL BE MADE ACCORDING TO MANUFACTURER'S INSTRUCTIONS AND DRAWINGS.
GLASSCRAFTERS RECOMMENDS THE INSTALLATION TO BE PERFORMED BY A TRAINED INSTALLER.

888-683-1362



















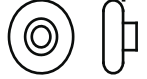

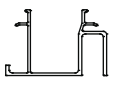
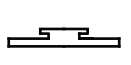

For 1/4" GLASS

Item No.	Description	Qty.
#1	Header	1
#2	Base	1
#3	Wall Jamb	2
#4	Glass Door	1
#5	Glass Door	1
#6	Base Vinyl	1
#7	Jamb Bumper	2
#8	#6 x 1/2" Screw	2
#9	Roller	4
#10	Glass Hanger	2
#11	Wall Anchor	6
#12	#8 x 1 1/4" Screw	6
#13	Towel Bar Pack	1 Set
#14	Center Guide	1
#15	Header Filler	1
#16	Safety Stop	3
#17	10-32 x1/2 Screw	4
#18	Set Blocks	2
#19	3/8" Channel	2
#20	180 Deg Inline Post	1
#21	Glass Panel	1
#22	Base Channel	1

FOR 3/8" GLASS

Item No.	Description	Qty.
#1	Header	1
#2	Base	1
#3	Wall Jamb	2
#4	Glass Door	1
#5	Glass Door	1
#6	Base Vinyl	1
#7	Jamb Bumper	2
#8	#6 x 1/2" Screw	2
#9	Roller	8
#10	Glass Hanger	2
#11	Wall Anchor	6
#12	#8 x 1 1/4" Screw	6
#13	Towel Bar Pack	1 Set
#14	Center Guide	1
#15	Header Filler	1
#16	Safety Stop	3
#17	10-32 x1/2 Screw	4
#18	Set Blocks	2
#19	3/8" Channel	2
#20	180 Deg Inline Post	1
#21	Glass Panel	1
#22	Base Channel	1

CAUTION: Risk of injury or product damage. Do not attempt to cut tempered glass.
IMPORTANT! Children should be supervised at all times while in Tub/Shower Enclosure.
IMPORTANT! Never use Door Handle to support yourself. This is for towels or wash cloths only.
PLEASE STOP THE INSTALLATION AND CONFIRM WITH FACTORY IF THE ACTUAL NUMBER OR TYPE OF PARTS IS DIFFERENT.

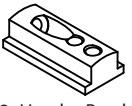
								
#1- Round Header	#1- Flat Header (optional)	#2- Base	#3- Wall Jamb	#6- Base Vinyl 3/8" Glass	#6- Base Vinyl 1/4" Glass	#7- Jamb Bumper	#8- 6x1/2" Screw	#9- Roller
								
#11- Wall Anchor	#12- 1 1/4" Screw	#14- Center Guide	#15- Header Insert	#16- Safety Stop	#17- 10-32 x 1/2" Machine Screw	#18- Setting Block	#19- Wall Channel	#20- Inline Post
								
#22- Base Channel	#23- Glazing Vinyl comes with 1/4" Inline panel	#24- Wall and Base Filler (if applicable)	#25- Set Of Towel Bars	#26- 1 1/4" Screw	#27- 6x3/8" Screw	#28- Header Bracket		

Tools Required - For installation of Your Shower Enclosure

- | | | | |
|--|--------------------------|---|-----------------------------|
| A - Safety glasses. | E - Miter Box or Square. | I - Drill bit, 1/8" | J - Power screwdriver |
| B - Measuring tape. | F - Level. | (for installation on a fiberglass enclosures) | K - #2 phillips screwdriver |
| C - Pencil. | G - Electric Drill. | Drill bit, 3/16" masonry | L - Caulking gun |
| D - Hack saw or chop saw (with carbide teeth). | H- Center Punch | (for installation on ceramic tiles or marble) | |

When ordering replacement parts, please specify the Model Number, Item Number & Part Description.

Save these Installation Instructions For The Future Reference.

Write your Dealer information down on Notes Section.

Ask your Dealer for JOB LOG NUMBER (Lxxxxxx-xxx) Referencing to your shower enclosure.

Installation shows 3/8" glass by-pass shower enclosure with two standard towel bars. Other units may vary.

Installation shows Round Header. Flat header is Optional.

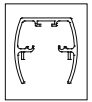

ROUND HEADS SECTION

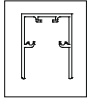

FLAT HEADS SECTION

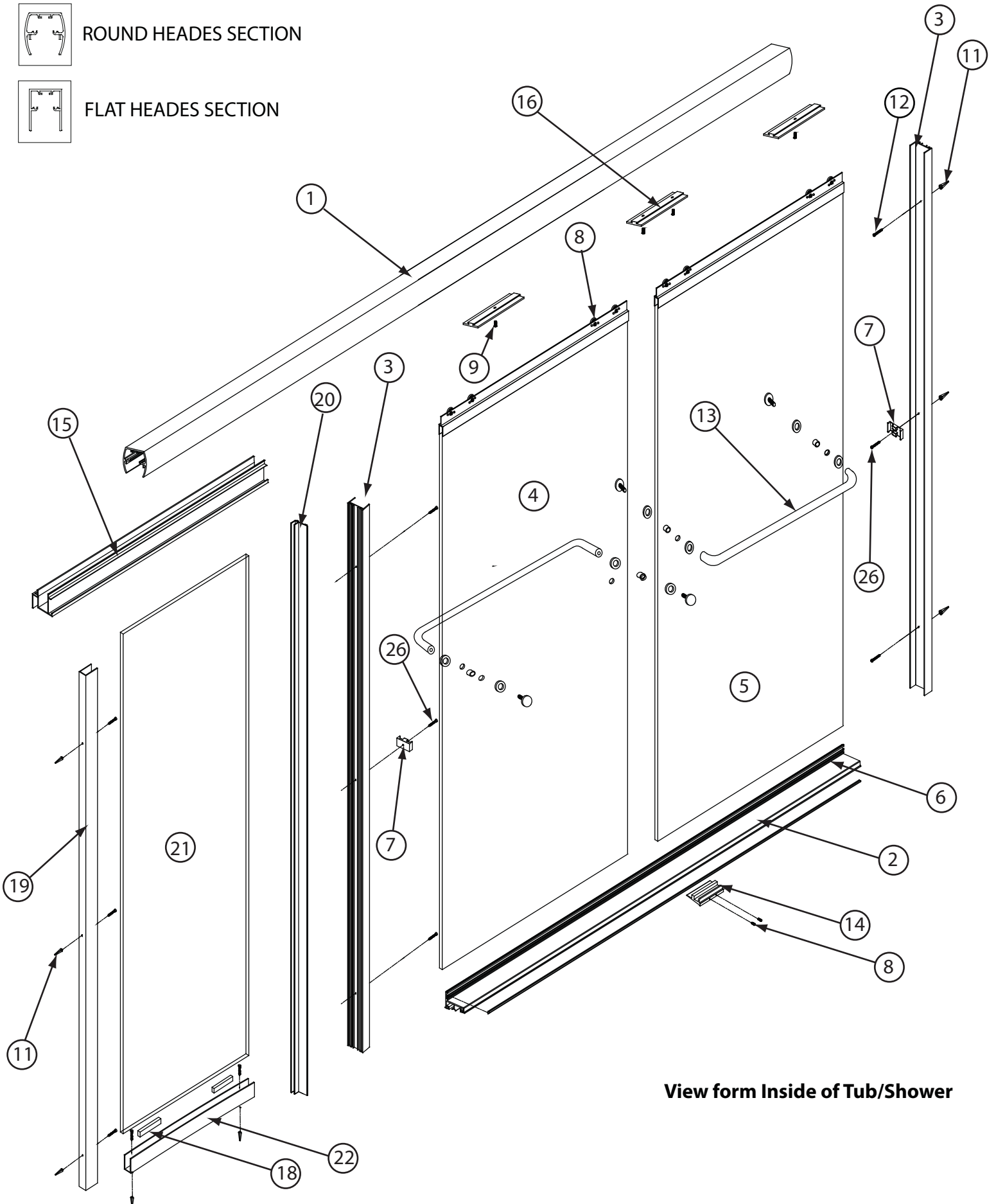

View from Inside of Tub/Shower

Installation Instructions for Glass Crafters Epic By-Pass Shower Enclosure

IMPORTANT: Read all instructions carefully and become familiar with all parts before installation.

Unpacking: Care should be taken unpacking your Shower Enclosure. Place the Glass Panels in an upright, Safe location to avoid damage. Never place glass directly on hard surface.

A Box cutter should not be used to open box.

Please remove all staples from the box prior to unpacking metal and glass.

Cleaning: Never use scouring powder, pads or sharp instruments on metal work or glass panels. We recommend the use of a squeegee after each shower to eliminate water spots on the inside of the glass panels.

An occasional wiping down of the glass panels and anodized aluminum parts with a mild detergent, diluted in water, is all that is needed to keep your Shower /Tub Enclosure looking brand new.

1

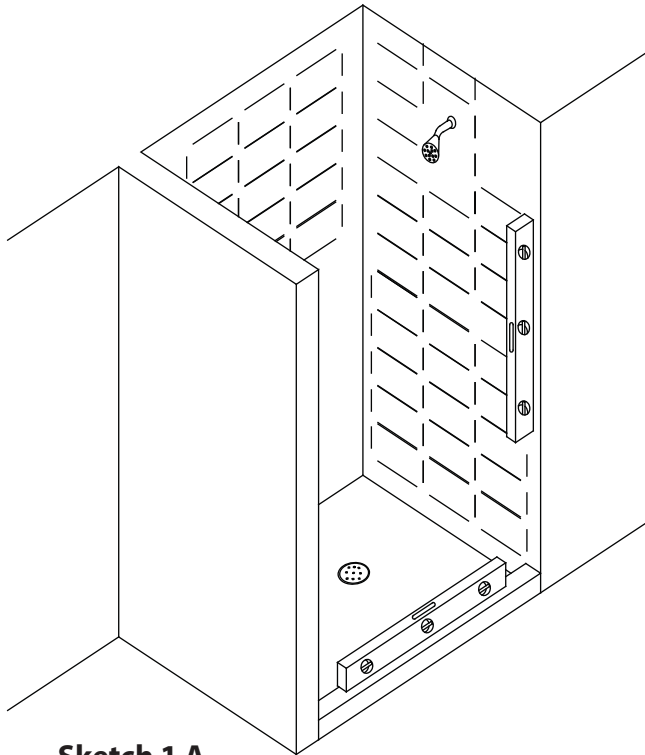

Sketch 1 A

IMPORTANT:

Determine if your Tub/Shower Stall Enclosure ledge is Level and Wall are plumb as shown in **Sketch 1A**.

If they are out of Level/Plumb, by more than 1/4", **STOP!** and call Customer Service. The Phone number is

1-888-683-1362

A Base filler and /or Wall Jamb Filler are recommended for obtaining proper adjustment;

both are available through Customer Service.

If they are Level/Plumb, or out of Level/Plumb for less than 1/4" proceed with installation.

2

Set the Wall Channel #19 on the wall and mark holes for screw anchors (**Sketch 2A**). Use Level to make sure that Channel is plumb. Remove the channel. Drill all marked holes and, clean the Tub/Shower Enclosure ledge and the Wall Jamb areas thoroughly. Insert Wall Anchors #11 into the drilled holes and install Wall Channel using Screws #12 as shown in **SKETCH 2B**. Do not apply Silicone Sealant to the back side of the Wall Channel Sealing the Wall Channel will be completed in the final step.

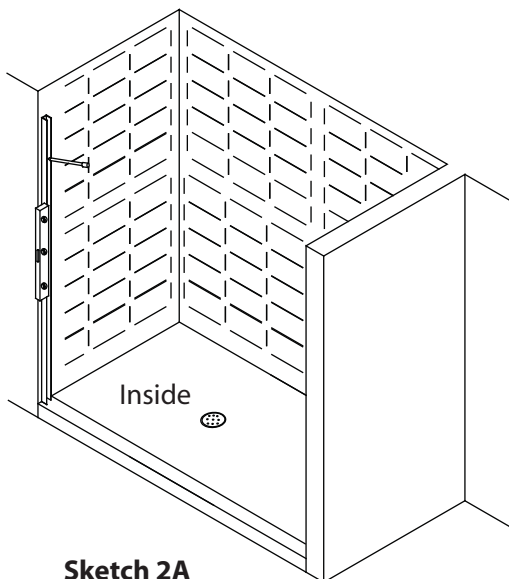

Sketch 2A

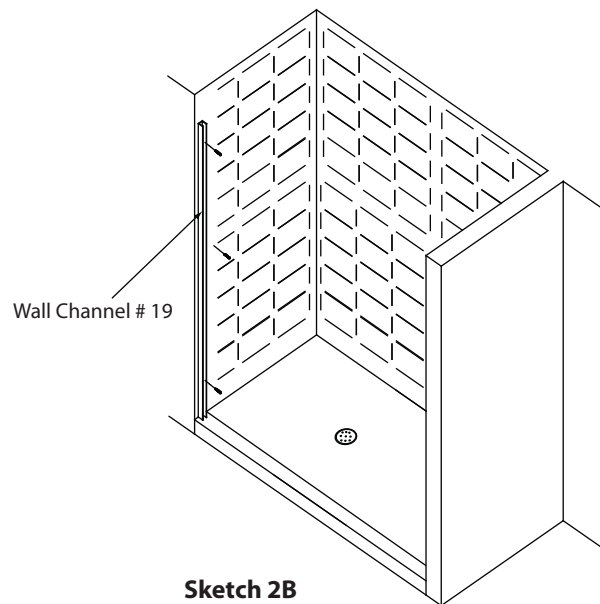

Sketch 2B

3

Channel #22 is cut to size on factory.

Set the Base Channel #22 on the base and mark holes for screw anchors (**Sketch 3A**).

Remove the channel. Drill all marked holes and, clean the Tub/Shower Enclosure ledge and the Base Jamb areas thoroughly. Insert Wall Anchors #11 into the drilled holes and install Base Channel using Screws #12 as shown in **Sketch 3B**. Do not apply Silicone Sealant to the back side of the Wall Channel Sealing the Wall Channel will be completed in the final step.

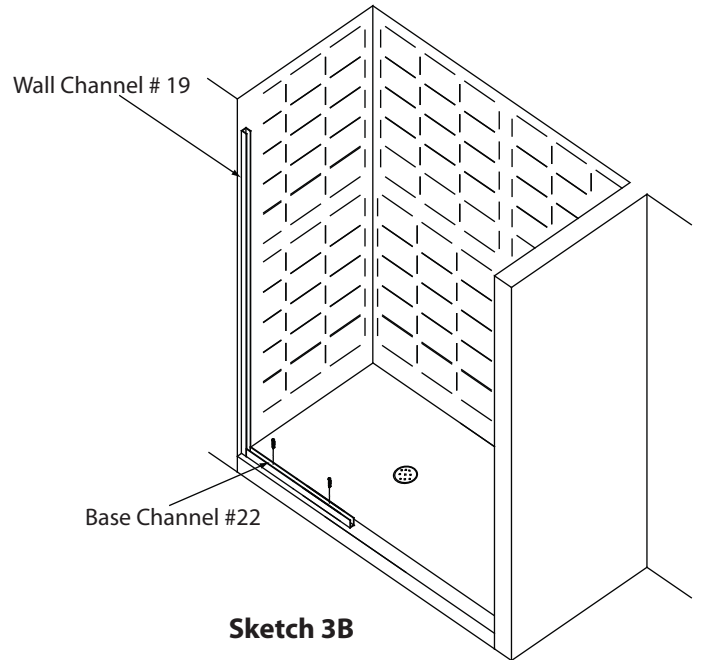
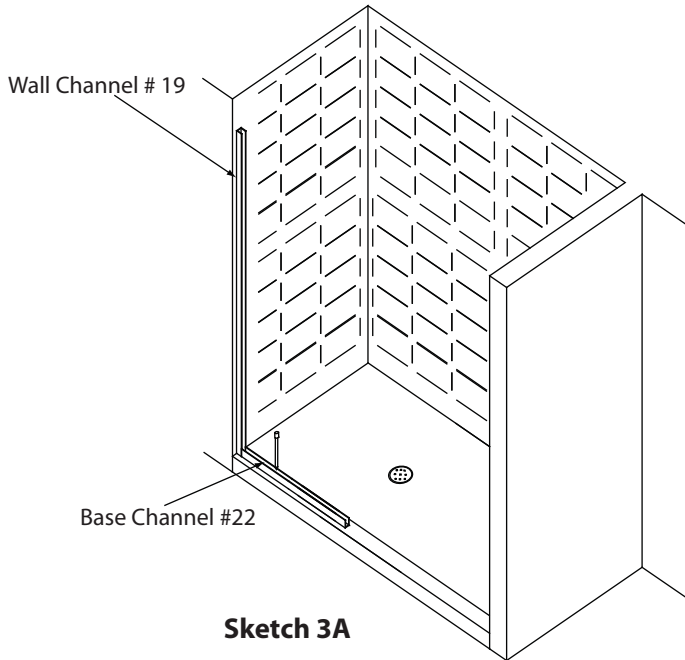
**4**

Wall Jamb # 3 is cut per size on factory.

Place a 1/16 shim on the corner by opposite wall, where wall jamb#3 will be installed

Position Wall Jamb #3 on top of 1/16 shim (**Sketch 4B**). Make sure that the front face of Base Channel #22 and front face of wall jamb #3 are on the same plane (**Sketch 4A**). Mark locations of wall anchors.

Remove Wall Jamb #3 and drill the marked holes. Clean the Tub/Shower Enclosure ledge and the Wall Jamb areas thoroughly. Secure Wall Jamb #3 with screws #12 using top and bottom hole.

For middle anchor use screw #26 and Jamb Bumper # 7 .See **Sketch 4B** for detail.

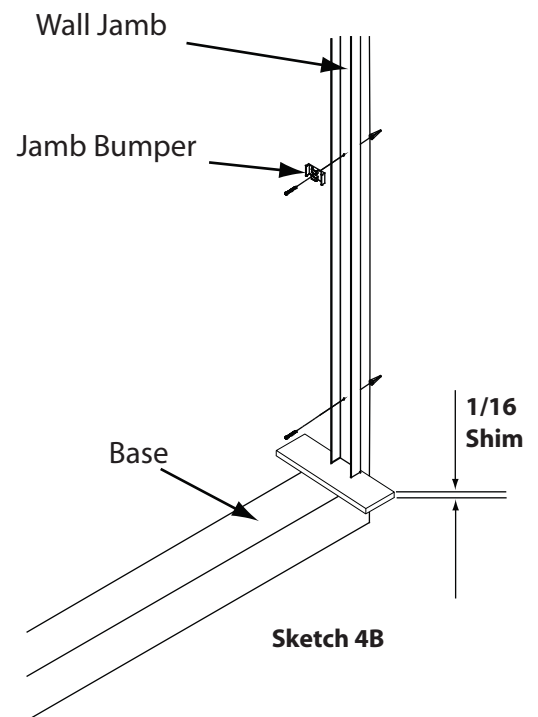
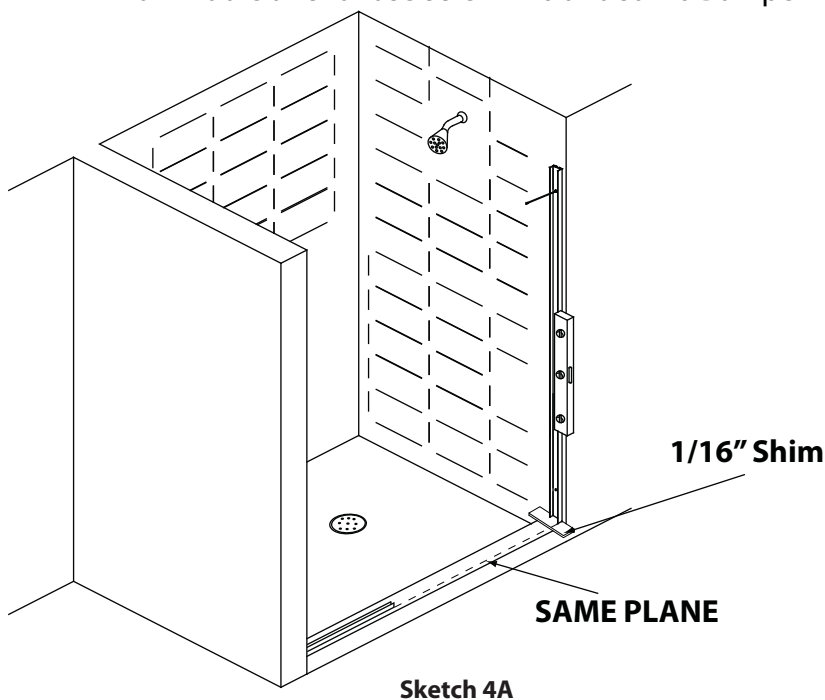

5

Base #2 is left oversized on factory and must be cut on job site.

Measure dimension "D" from end of base channel #19 to opposite wall (**Sketch 5A**). Subtract 1 ¼ from dimension "D". The result is the exact size for Base #2. Cut Base #2 to size.

Please Note: to obtain the best results, use a carbide tooth metal cutting chop saw or metal hack saw.

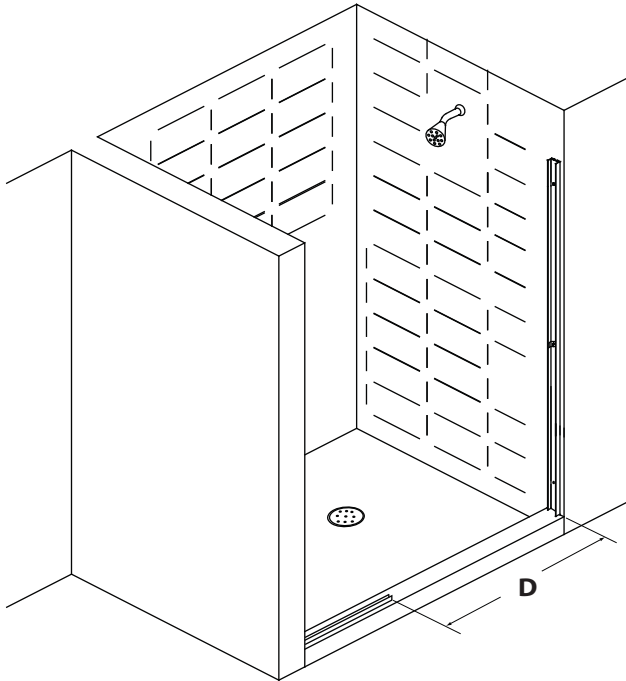

Sketch 5A

Apply a thick continuous bead of Silicone Sealant to the underside of the Base, as shown in **SKETCH 5B**.

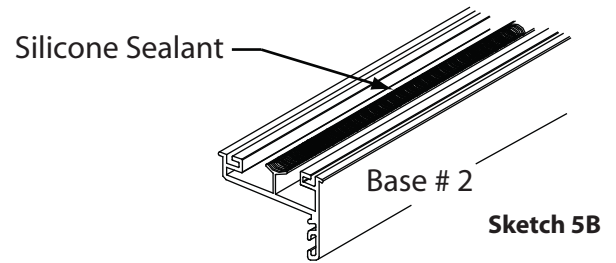

Sketch 5B

Remove 1/16" shim from under the Wall Jamb #3. Set the Base #2 on the curb fitting it **UNDER** and **IN** wall jamb #3, as it shown on **Sketch #5C**. It gap under wall jamb#3 is not big enough for Base #2 to slide, loose the fastening Screws #12 and #26 on Wall Jamb#3 and shift it up.

When Base #2 is set, use a clean paper towel to wipe off the exes silicon from curb.

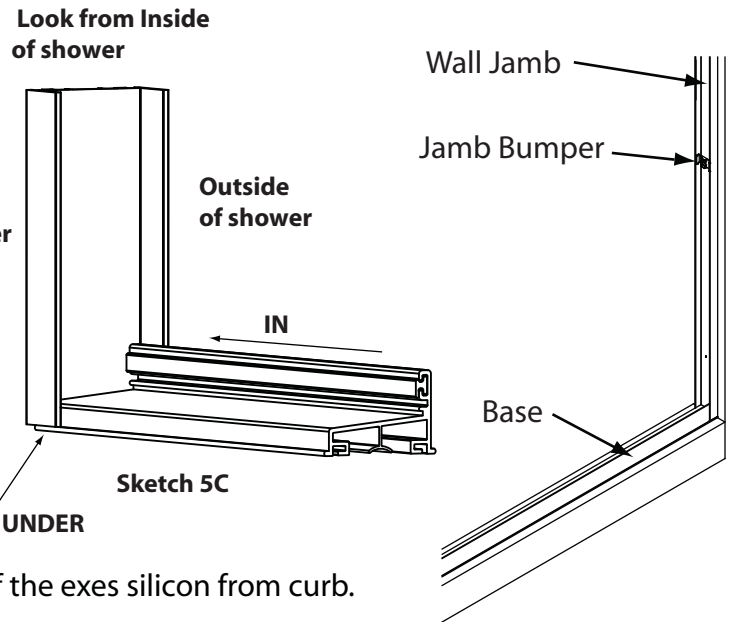

Sketch 5C

6

Place Setting Blocks #14 into Base Channel# 22. **Sketch # 6A**

Carefully Set the Glass Panel into Wall Channel #19 and Base Channel #22. **Sketch # 6B**

Be careful not to chip or strike the glass edges. Glass can brake if edges are not handled properly.

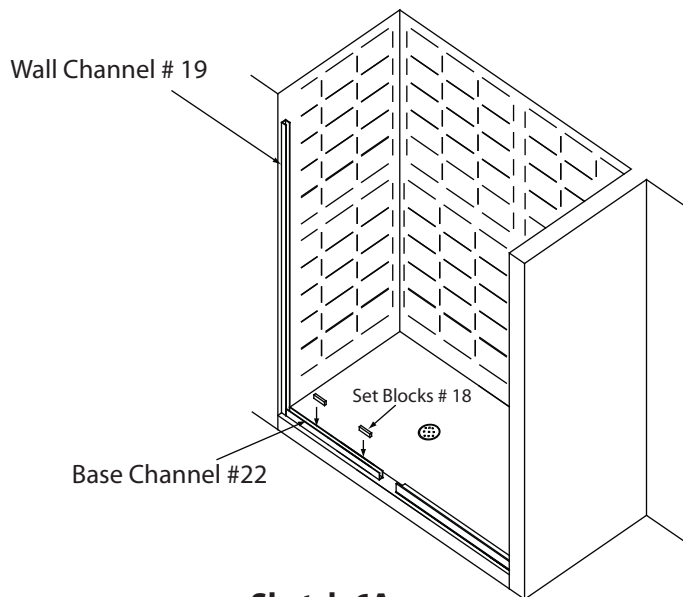

Sketch 6A

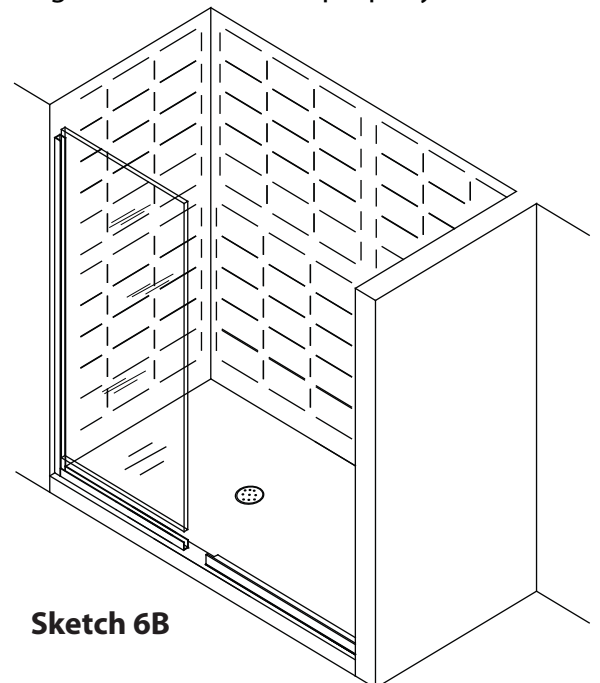

Sketch 6B

7

Carefully slide into temporary position 180 deg inline post # 20 and wall jamb # 3 as shown in **Sketch # 7A**
 Use level and tape-measure to make sure that 180 degree post is plumb.
 Use few strips of masking tape to secure the extrusions and the glass.

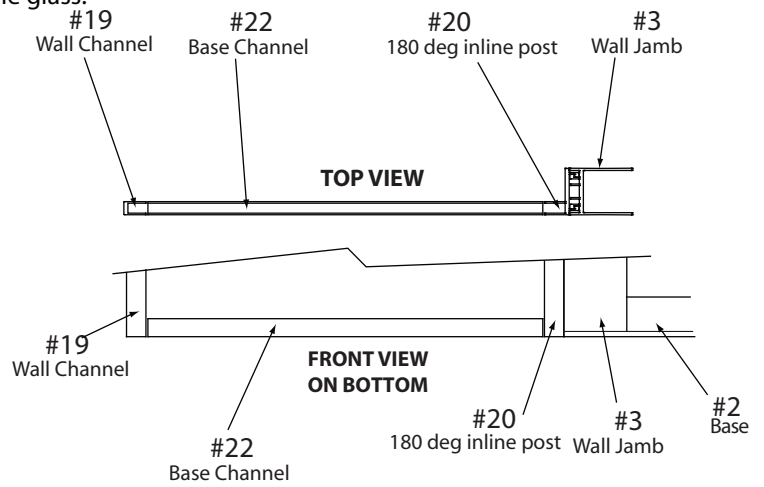
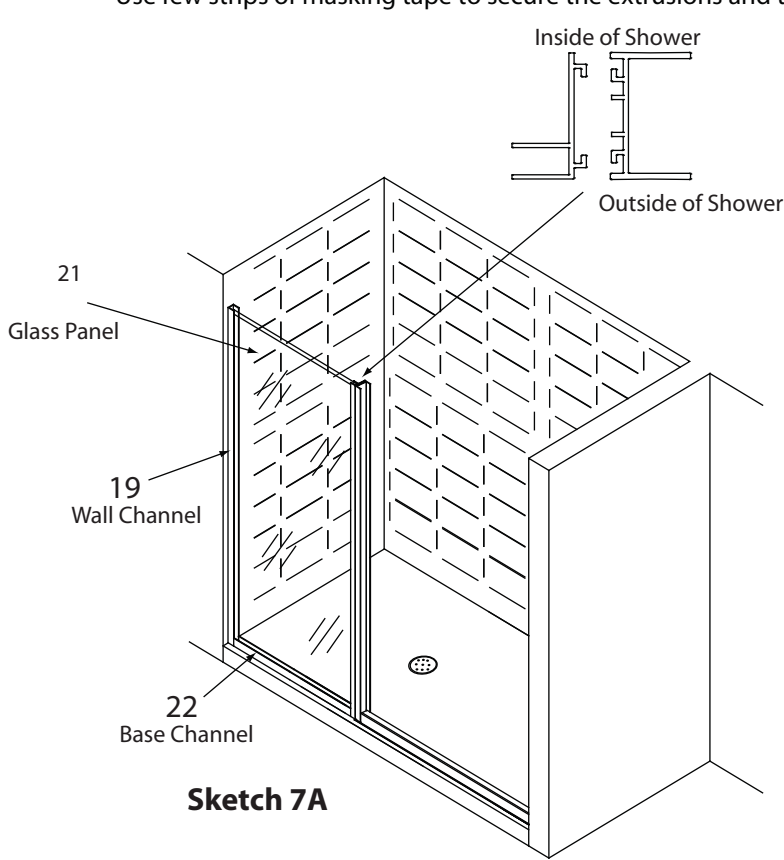

When installed properly 180 degree post should look like it shown on Sketches 7B and 7C

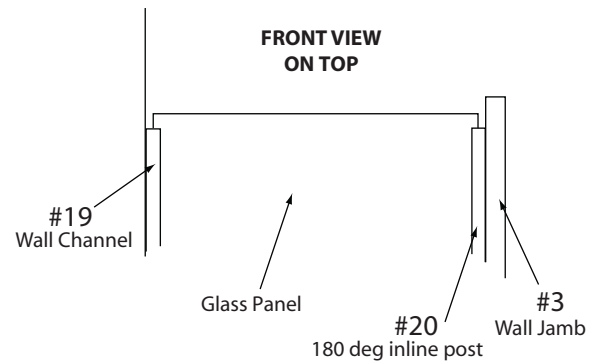

SKETCH 7C.

8

Header Bracket must be installed on Stationary Panel side of the Unit.

Measure dimension "C" from wall to wall on top of the Glass, as shown on Sketch # 8A. Subtract 1/16 from size "C". that is the size of the Header #1.

Cut Base# 2 to size. Please Note: to obtain the best results, use a carbide tooth metal cutting chop saw or metal hack saw. Insert Header Bracket# 28 into the Header#1. (**Sketch 8B**)

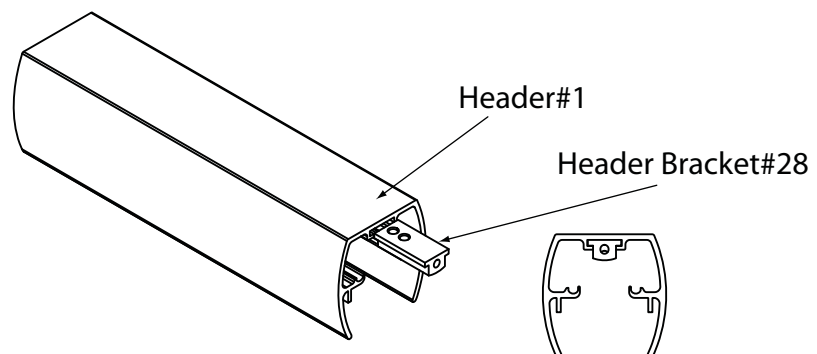
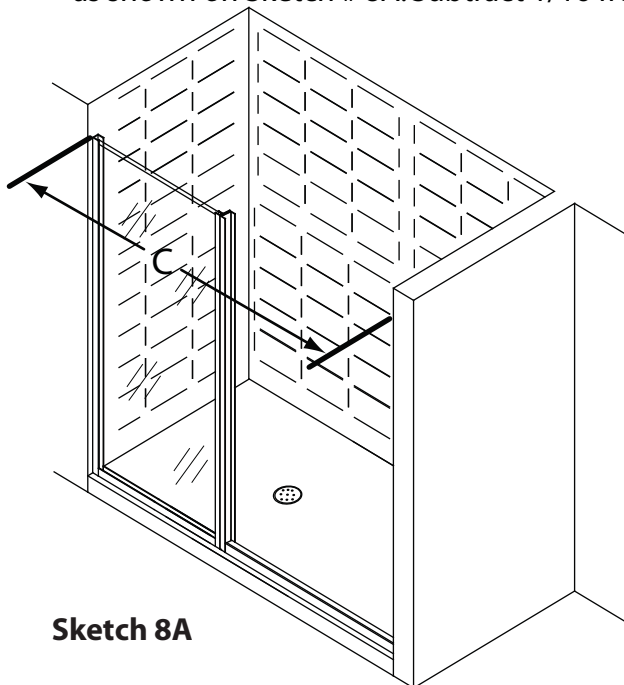

9

Set Header #1 on wall Jams#3 (**Sketch 9A**). Use a level to make sure header is level. Mark hole location for Header Bracket#28. Remove Header#1, Drill the hole and insert Anchor#11. Working from inside of the hower will make the access to bracket easier.

Mark Header Bracket hole locations here.

Sketch 9A

Measure dimension "F" as it shown on the **Sketch #9B**. That is the size for a Header Insert#15. Cut the Header Insert#15 to size. To obtain the best results, use a carbide tooth metal cutting chop saw or metal hack saw. Put Header Insert #15 aside for future use. Remove the 180 degree post #20 with Wall Jamb #3 from meadle Be careful not to hot the Glass.

FRONT VIEW
ON TOP

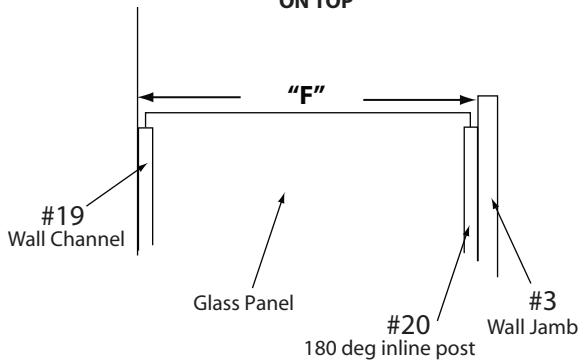

SKETCH 9B.

10

Open Safety Stop Package. Insert Screws into safety stops as shown in **Sketch 10A**. Insert Safety Stops into Header as shown in **Sketch 10B**. Make sure to insert Safety Stop with 2 holes as shown in **Sketch 10 C**

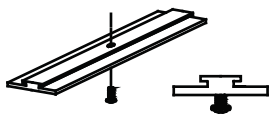

Sketch 10 A

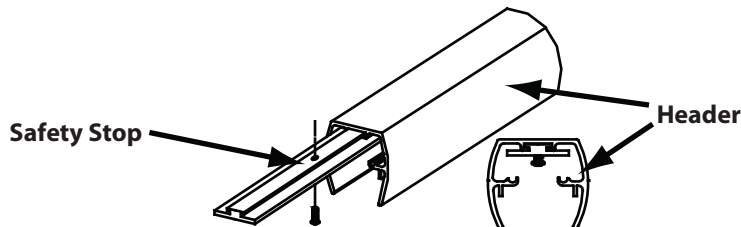

Sketch 10 B

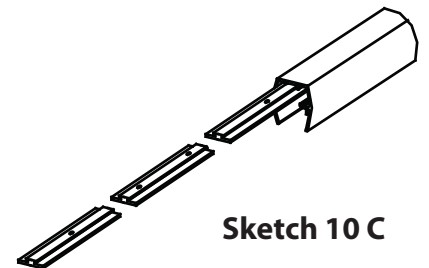

Sketch 10 C

11

Insert Header Filler # 15 as shown in **Sketch 11 A** away from panel location.
 Slide the Header down on top of the Wall Jamb #3 and Wall Channel #19 as shown
 Using an long screwdriver insert and fasten Screw# 12 into the Header Bracket #28
 Slide the Header Insert#15 over Glass Panel until it reaches the end of the Header.
 Using an long screwdriver insert and fasten the screw# 11 into the Header bracket #28. Slide the Header Insert#15 over Glass Panel until it reaches the end of the Header. Install back previously removed 180 Degree Post#20 and Wall Jamb#3

Round Header shown. Yours may Differ.

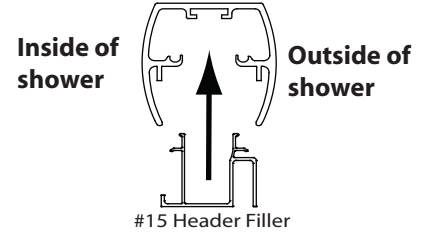
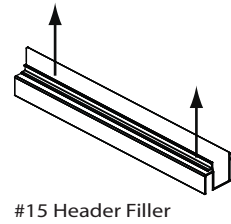

Sketch 11 A

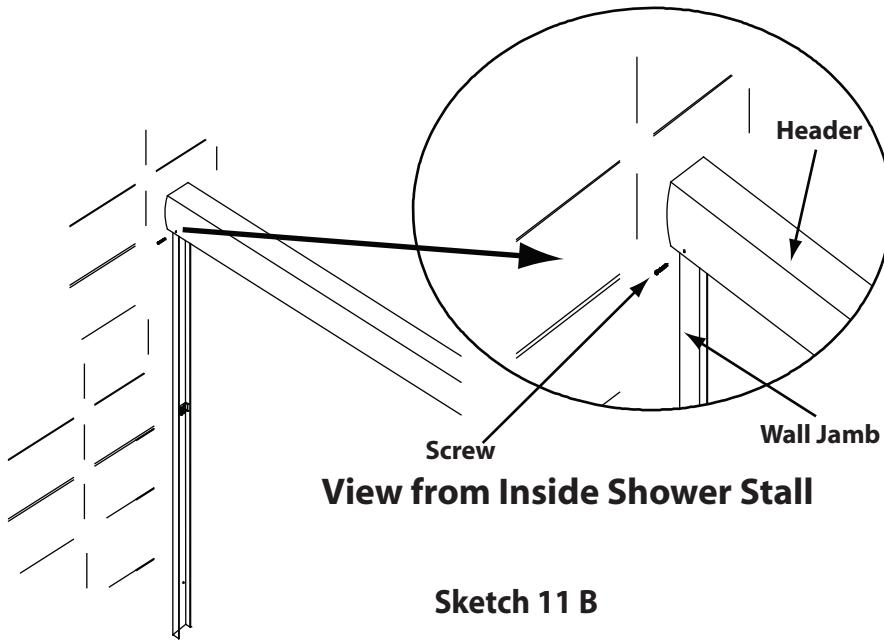

Sketch 11 B

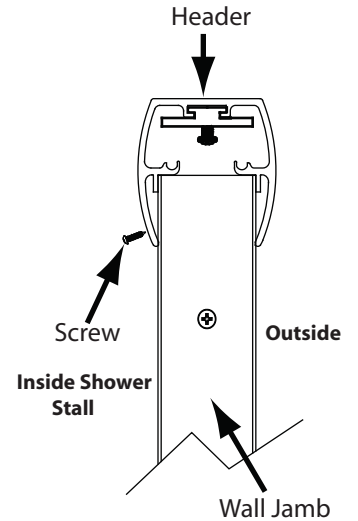

Sketch 11 C

Standing inside of the shower Drill and fasten Screw # 27 through the Header#1 into both Wall Jamb#3; on wall side and Wall Jamb #3 in the middle of unit. (**Sketch 11B and 11C**)

12

TOP VIEW

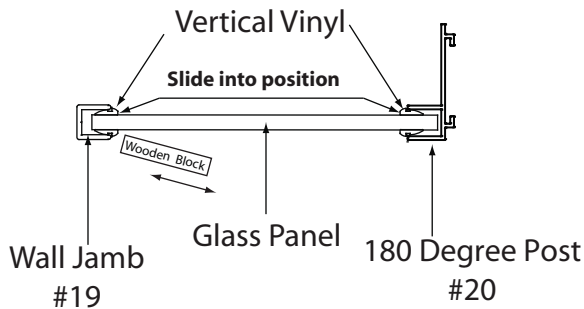

Sketch 12A

NOTE: A light spray of Glass Cleaner on the glass will help the vinyl slide into position. Flat square block of wood can be used to tap in vinyl.

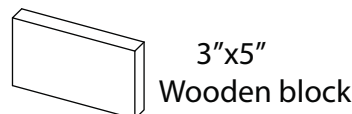

Insert Glazing Vinyl# 23 into Wall Channel #19, Header Insert#15 , Base Channel #22, and 180 Degree Post #20. See **Sketch#12A** and **12B** for details. Use a wooden Block to tuck the vinyl in.

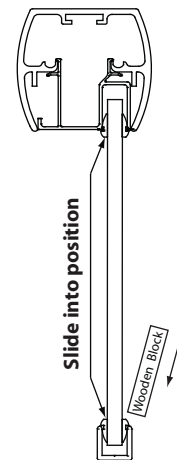

Sketch 12B

13

Glass hangers are installed on to glass panels at factory.

Warning: The Glass Panels are heavy and awkward. It is recommended that two people lift and hang the glass panels.

DO NOT LIFT GLASS PANELS BY THE TOWEL BARS/PANEL PULLS.

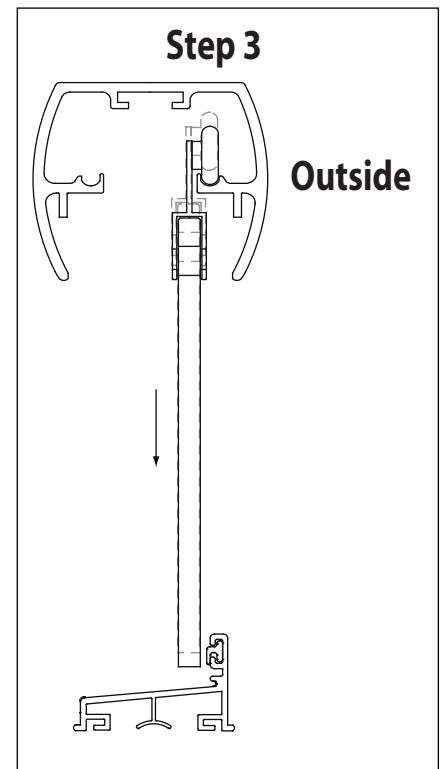
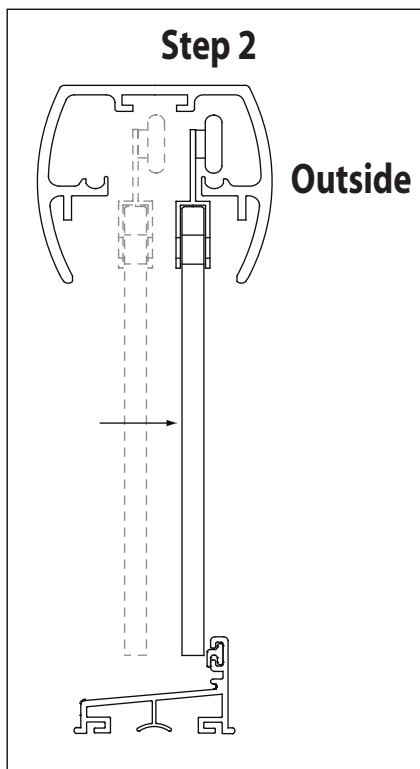
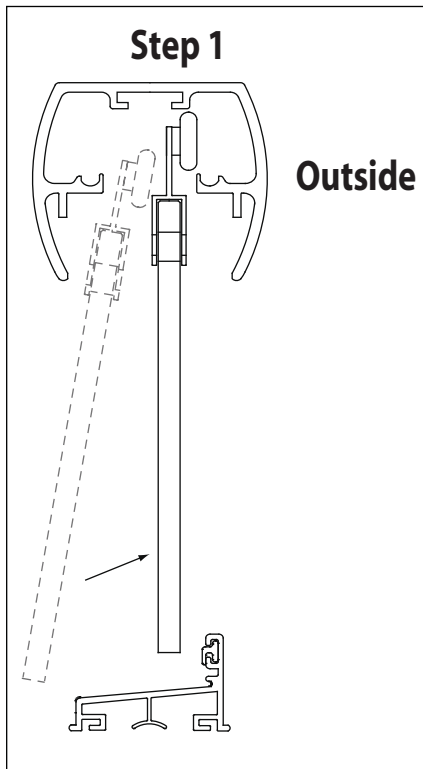

Slide Safety Stops to one side before attempting to install Glass Panels.
Panels will not fit into Header with Safety Stops on the way.

Installing the Outer Glass Panel.

Standing inside of the Tub/Shower, Position the Glass Panel on front of Tub/Shower Enclosure with the Rollers facing OUT Tub/Shower Enclosure.

Holding the Glass Panel by the sides, lift it up into the underside of the header, between roller ledges. Working under a slight angle will make it little easier. **(Step 1)**

With the Glass Panel in vertical position move it toward the outer Track Ledge **(Step 2)** making sure that rollers are above the ledge. Bring the glass down; let the rollers to get on the ledge and inside the track **(Step 3)**.

Slowly release, allowing the glass panel to hang freely from the header.

At this point if released, glass will not hang vertically, but under an angle.

While Holding the Glass vertically Slide the Glass Panel back-and-forth in the track.

Make sure that the rolling is smooth and easy.

Glass hangers are installed on to glass panels at factory.

Warning: The Glass Panels are heavy and awkward. It is recommended that two people lift and hang the glass panels.

DO NOT LIFT GLASS PANELS BY THE TOWEL BARS/PANEL PULLS.

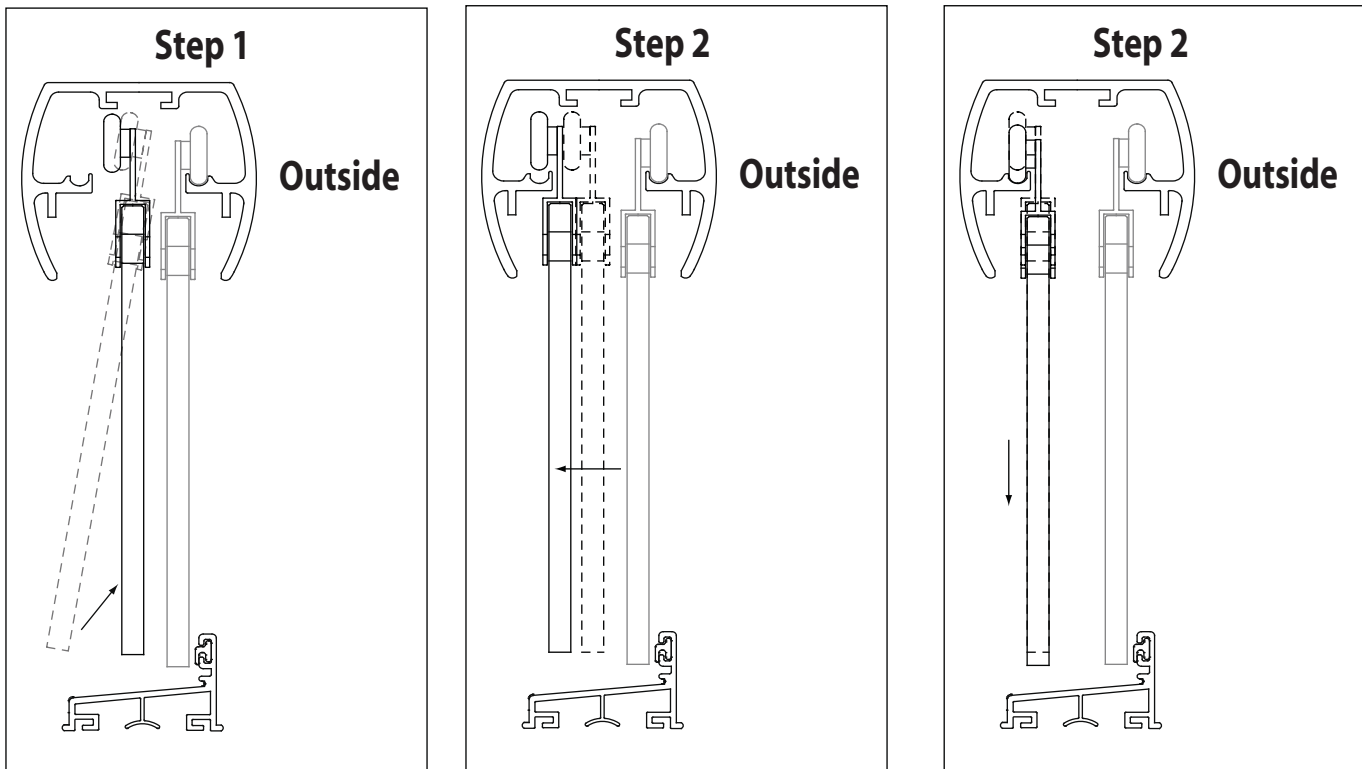

Slide Safety Stops to one side before attempting to install Glass Panels.
Panels will not fit into Header with Safety Stops on the way.

Installing the Inner Glass panel.

Standing inside of Tub/Shower, Position the Glass Panel on front of Tub/Shower Enclosure with the Rollers facing IN Tub/Shower Enclosure. Holding the Glass Panel by the sides, lift it up into the underside of the header, between roller ledges.

Working under a slight angle will make it little easier. **(Step1)**

With the Glass Panel in vertical position move it toward the inner Track Ledge making sure that rollers are above the ledge. Bring the glass down **(Step2)**, letting rollers to get on the ledge and inside the track **(Step 3)**. Slowly release, allowing the glass panel to hang from the header. At this point, if released, glass will not hang vertically, but under an angle.

While Holding the Glass vertically Slide the Glass Panel back-and-forth in the track.

Make sure that the rolling is smooth and easy.

The Inner Glass Panel must be located on shower head side.

15

There should be 1/4-5/8 space between bottom edge of the glass and Base (Sketch 10A).

That space is necessary for Center Guide.

If it is less or more than mentioned limits the rollers must be moved up/down.

Readjusting Rollers on the Glass Hanger.

NOTE: this step is only performed if necessary.

Remove Glass Panels from Header with same movement repeated backwards.

Please note there are a set of pre-drilled holes on hanger, **Sketch 15B**.

Using screwdriver, loosen and remove the screws that fasten rollers and hanger.

Move the rollers up or down to desired location. Fasten the screws back.

Make sure that screw is tight and roller

will not come off the hanger during the use.

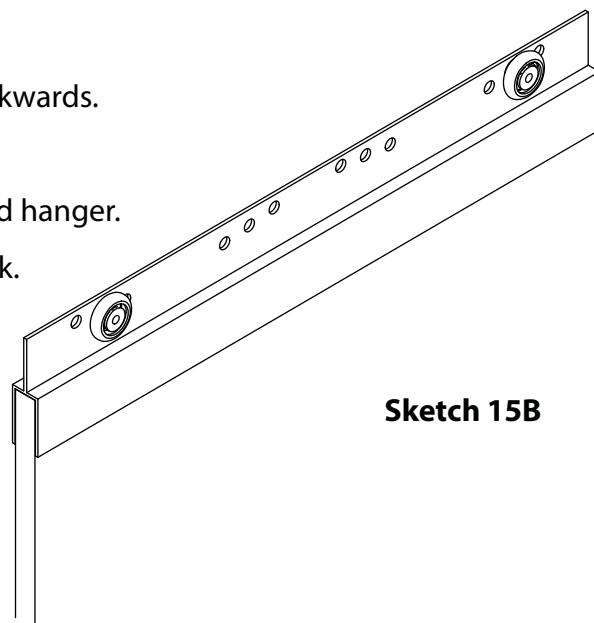
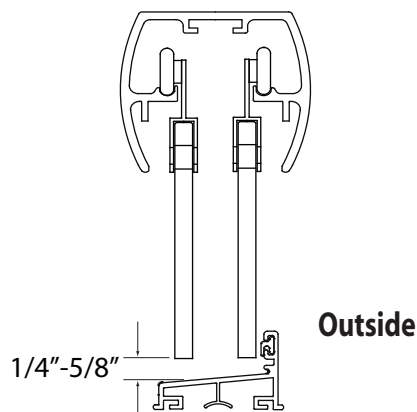

Sketch 15B

16

Installing Bottom Guide.

Stand inside the Tub/Shower Enclosure and slide both glass panels to one side of the enclosure.

Install the center guide by sliding it to the center of the base.

Carefully drill 1/32\" holes and insert screws as shown in **SKETCH 16A**

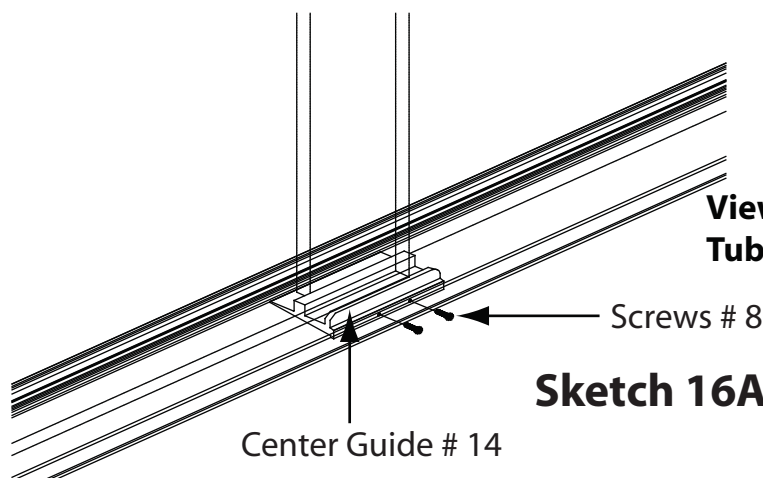

**View looking from inside
Tub/Shower Enclosure**

Sketch 16A

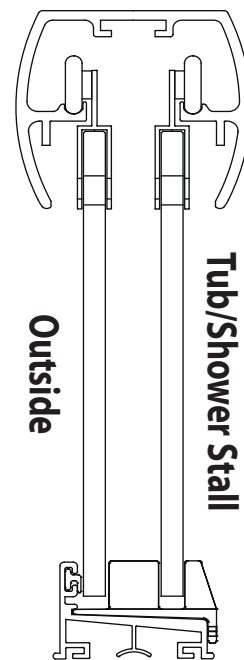

Clean the metal perimeter free from dust and construction debris.

Apply Silicone Sealant as shown

Be sure to add Silicone to both ends of the Base where it meets the Wall, as shown in **SKETCH 13 A.**

Please note that after applying Silicone Sealant, it must not be used for 24 hours to allow the sealant to set properly.

It is essential that Silicone Sealant be applied at all locations indicated inside and outside, as shown in **SKETCH 17 B.**

Apply a bead of Silicone Sealant to Glass Panel Inside and Outside as shown in **Sketch 17 B.**

It is essential that Silicone Sealant be applied at all locations indicated by dotted lines, as shown in **SKETCH 17 A.**

Apply Silicone Sealant both ends

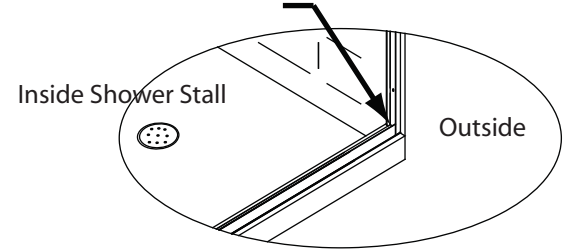

SKETCH 17 A

Apply Silicone Sealant Inside and Outside

Please note : After applying Silicone Sealant, it must not be used for 24 hours to allow the sealant to set properly.

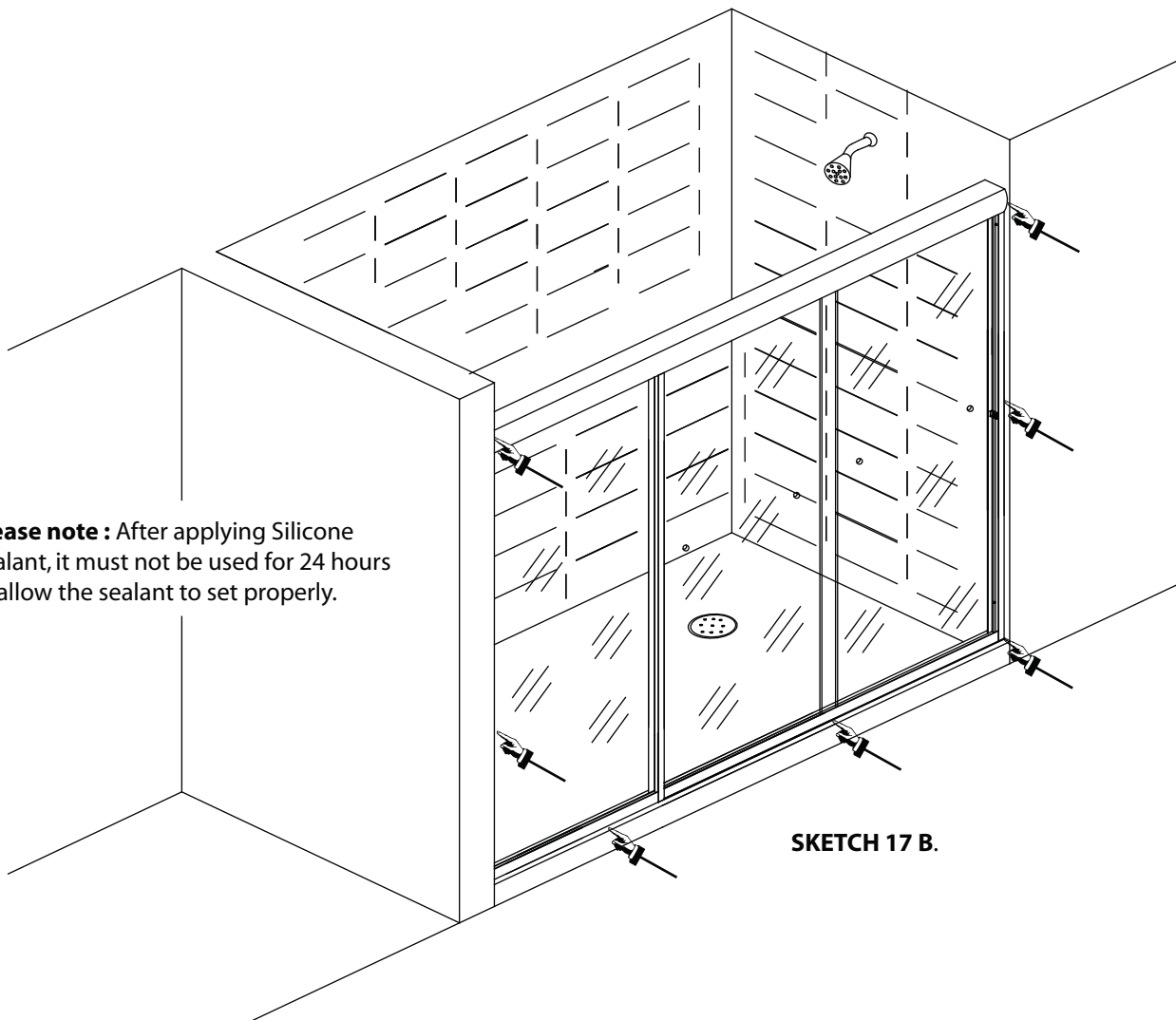

SKETCH 17 B.